



A PerTronix Performance Brand ~ www.pertronixbrands.com ~ 909 599-5955

Installation Instructions & Warranty Information

D380 ~ 1965 – 1982 Corvette 265-400 Small Block
Side Tube Long Tube Headers

NOTE: These headers require the purchase of the side pipes (#D930, D930-C, or D930B) and mufflers (D950, D951, or D952).

If your alternator/generator is mounted to the exhaust manifold you will need to purchase bracket #H7606.

1965-82 A/C models need A/C bracket #H7608.

These headers do not accommodate smog air injection tubes, if you are retaining an air pump with injection tubes, these headers will NOT work.



2

This product is legal for use on 1975 and older Non-Catalyst equipped vehicles and is considered a "Replacement Part" per California Air Resources Board regulations, providing ALL emissions sensitive components are retained, including EGR, A.I.R., Heat Risers, etc. and any original or retrofit PCV or NOx device is required for the year of the vehicle. Failure to retain any of these components, or use on ANY originally catalyst equipped vehicles, would render this product illegal for street or off highway use and may only be used for Closed Course Competition.

⚠ WARNING:

This product can expose you to chemicals including Lead, Nickel, Cadmium and Chromium which are known to the State of California to cause cancer and birth defects or other reproductive harm. For more information go to www.P65Warnings.ca.gov

PLEASE READ BEFORE PROCEEDING

PerTronix® thanks you for choosing a Doug's Headers Product. To realize the potential of Doug's Headers engineering and excellent fit, Please Read and Understand these instructions completely prior to starting the installation.

Check that you received all the parts listed on the parts list, if you have any concerns, please contact PerTronix before continuing. Headers will have the part number stamped in the flange.

Many factors affect the installation of exhaust headers, including worn or aftermarket motor mounts, previous accident damage, aftermarket cylinder heads that may have relocated port or spark plug locations, suspension and steering changes, sagging of original unibody structures due to age.

Coating Notes: Coatings can be marred during installation if you are not careful. If you are breaking in a new motor, the extreme heat can alter the appearance of the coating and this is not a warranty issue. We recommend breaking in new motors with stock manifolds or an old set of headers.

We use sealing beads on all our headers. The raised bead creates a better seal virtually eliminating leaks if installed properly. It is important to install all header bolts lightly snug and then tighten to factory torque specs starting in the center and working outward.

Before starting, allow the vehicle to cool, disconnect the battery, and spray a penetrating oil on all hardware and fittings that will need to be removed. Once you remove your manifold, clean the sealing surface on the head of any old gasket debris or carbon build up.

Work Smart – Work Safe! Most Header and Exhaust Installation are best performed on a lift. If a lift is not available, raise the vehicle and support on quality Jack Stands on level ground. Do not rely on a jack!

DISASSEMBLY

1. Unbolt the stock Headpipes from the manifolds and remove the pipes and mufflers from the car.
2. Remove the generator or alternator, remove the A/C compressor, Spark Plug wires and Spark plugs, Clutch Z Bar (if manual transmission)
3. Remove the stock Exhaust manifolds or existing headers.
4. Remove the rocker arm panel molding. The rocker panel will need to be modified as shown in the illustrations. Due to variances in cars and years, we recommend that the illustration only be used as a guide – check fit parts before cutting or trimming.

INSTALLATION

DRIVER SIDE

- 1) Starting from below, slip the driver's side header up into position. Slip the gasket between the head and the header and start all the header bolts but do not tighten at this time. Install the Alternator /generator bracket if mounted on driver's side at this time as well.
- 2) Install the muffler insert into the sidepipe. Install the rubber bushing into the tab bracket on the sidepipe. Slip the sidepipe onto the header collector. Check the position of the sidepipe brackets to the holes in the rocker panel. Trim the rocker panel as necessary. Due to Chevrolet manufacturing tolerances, it MAY be necessary to slot the holes in the sidepipe brackets in order for the sidepipe to slide completely onto the collector. This is not usually required.
- 3) Insert the 'T' bolt into the hole in the rocker panel. The rubber bushing will slide over the bolts and is secured with the flat washer and nut.
- 4) Tighten the header flange bolts evenly from the center out.

PASSENGER SIDE

- 1) From below, slip the passenger side header up into position. Slip the gasket between the head and the header and start all the header bolts but do not tighten yet. Install the Alternator/ Generator bracket if mounted on passenger side at this time as well.
- 2) If equipped with Air Conditioning:
 - a) 1965-76 will need A/C bracket #H7608.
 - b) 1963-64 models with A/C mounted on right side exhaust manifold will require a Hedman Heddars bracket #20020. This bracket will need to be modified slightly by removing approx. ½" from the front edge.
 - c) 1977 and later models will require reuse of the original A/C bracket and stud that fits the front first bolt hole. Fabricate a 3/8" i.d. X 5/8" o.d. X ¾" long spacer to fit between the header and the bracket.
- 3) Install the muffler insert into the sidepipe. Install the rubber bushing into the tab bracket on the sidepipe. Slip the sidepipe onto the header collector. Check the position of the sidepipe brackets to the holes in the rocker panel. Trim the rocker panel as necessary. Due to Chevrolet manufacturing tolerances, it MAY be necessary to slot the holes in the sidepipe brackets in order for the sidepipe to slide completely onto the collector. This is not usually required.
- 4) Insert the 'T' bolt into the hole in the rocker panel. The rubber bushing will slide over the bolts and is secured with the flat washer and nut.
- 5) Tighten the header flange bolts evenly from the center out, side pipe tab bolts and the pinch bolt on the front of the side pipe.
- 6) Reinstall the Clutch Z bar, Spark plugs and wires, Alternator/Generator, and A/C compressor,
- 7) Check all brake and fuel lines for clearance around headers and exhaust and relocate as necessary.
- 8) Connect the negative battery cable.
- 9) Start the car and check for leaks.

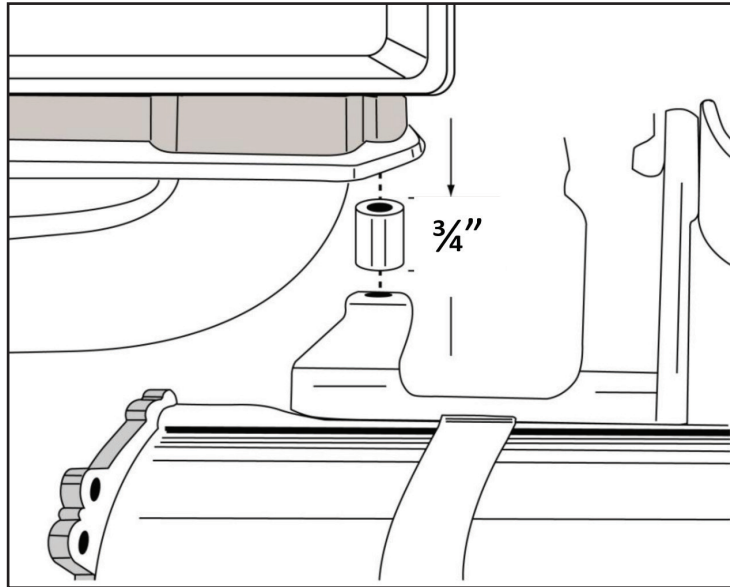

1977-82 Bracket Spacer

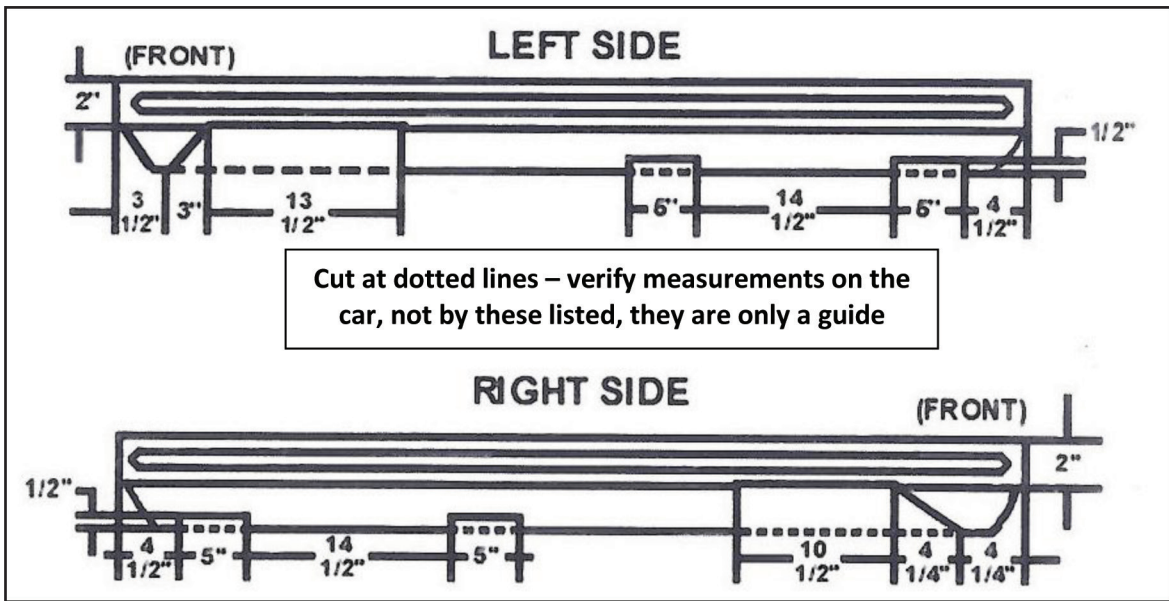

1963-67 Rocker modification

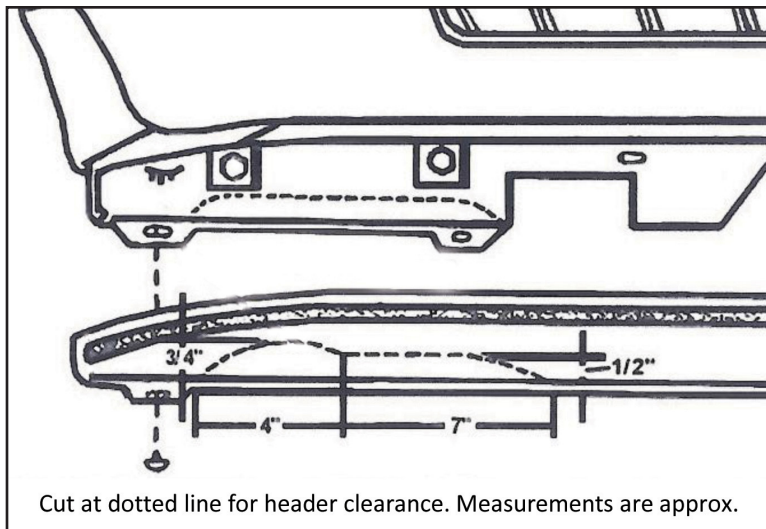

Cut at dotted line for header clearance. Measurements are approx.

1967-82 Rocker modification

IMPORTANT CHECK LIST

- Be sure that all brake lines, transmission lines, and fuel lines are clear of headers and/or connector pipes.
- All spark plug wires, battery cables, or other electrical components should be clear of headers and/or connector pipes.
- If dipstick tube was removed, make sure it is installed properly and that the dipstick has been replaced.
- Double-check the tightness of all bolts including brackets and accessories.

START THE ENGINE

Start the engine and allow it to warm up to operating temperature. Check for any unusual noises or exhaust leaks. If everything is OK, stop the engine and tighten all bolts while the engine is still warm. **NOTE:** Check the bolts periodically to make sure they have not loosened. Re-tighten after the first 500 miles and then again at 1000 miles

Parts List

1	Left side header	1	Right side header
2	Header gaskets	12	3/8 X 1", header bolts
12	Lock-washer	2	Doug's Stickers

DOUG'S HEADERS LIMITED WARRANTY

All Doug's Headers and Exhaust products are guaranteed, to the original purchaser, to be free of defects in material and workmanship for one year from date of purchase. This warranty covers the replacement or repair of the product and does not cover the cost of removal and installation, customer applied coatings, or Any discoloration or corrosion of finished surfaces.

Damage or product failure resulting from collision, improper installation, off road use, road hazards, the use of exhaust insulating wrap, or rust occurring after installation is not covered by the warranty. This warranty extends only to the original purchaser.

Should a part be deemed defective, it should be returned to the original selling retailer and must be accompanied by the sales receipt. If there is no retailer in your area, contact PerTronix direct for a return authorization and return the part prepaid to the factory for inspection. PerTronix reserves the right to replace or repair the alleged defective part and return the part freight collect.